



## INSTITUTE FOR DEVELOPMENT AND RESEARCH IN BANKING TECHNOLOGY

(Established by Reserve Bank of India)

Castle hills, Road No. 1, Masabtank, Hyderabad – 500 057

Ph: (040) 23294185 & 82; Fax: (040) 23535157; Ext. 1085

**IDRBT/EST/BSP/26.2.1/644/2016-2017**

**21.11.2016**

### **Supply, Installation, Testing and Commissioning of Street lights & Bollards System in IDRBT**

Sealed quotations are invited for Supply, Installation, Testing and Commissioning of Street lights & bollard system in IDRBT premises, and should be addressed to the Director, IDRBT, Masabtank, Hyderabad, so as to reach IDRBT not **later than 17.00 hrs on 28.11.2016 with an EMD of Rs 15,000/-**.

1. The Institute reserves the right to accept or reject any or all the quotations in full or in part without assigning any reasons thereof and also reserves the right to accept the quotation of any firm partly or fully.
2. The quotation shall be valid for a period of 30 days from the date of opening of the same.
3. The firm is requested to quote unit rates and amounts separately in the enclosed Performa (Bill of Quantity) only.
4. **The firm shall furnish Earnest Money Deposit in the form of a Demand Draft in favour of IDRBT, Hyderabad for a sum of Rs 15,000/-**. The EMD does not carry any interest and the same will be released after completion of Defects Liability Period (DLP) of one year from the date of completion of work to the successful bidder. Quotation, which is not accompanied by EMD in the form of DD, will not be considered. However, EMD will be returned to the unsuccessful bidder after placing the work order with successful bidder.
5. The rates quoted shall be inclusive of all taxes, duties, levies, transport, packing, forwarding charges, and including installation charges etc.
6. TDS will be deducted from the payments made to the firm.
7. The firm may consult Institute's ***Estate Officer (Cell:8019257133)*** and should thoroughly acquaint themselves with the nature and the scope of work ( same as per BOQ ) if required before quoting.
8. The entire Supply and Installation, Testing and Commissioning of street lights & bollards shall be completed strictly within 25 days from the date of work order, failing which **Liquidated Damages (LD) at the rate of 0.25% of the tender cost per week** for the delay in completion of work beyond the stipulated period with an upper ceiling of 5% of the contract amount will be levied.
9. The following terms of payment will apply to the contract.
  - a) 95% of the quoted rate will be released after completion work on actual measurement basis.
  - b) Balance 5% of the quoted rate will be released after expiry of defects liability period of one year.
10. The firm shall make good the damages caused to the Institute's property during the execution of the materials at no extra cost.

11. The firm shall be fully responsible for all type of loss, damages during the execution of the materials including mishap/accident to any person.
12. The firm should quote on the above terms and conditions as per the enclosed bill of quantities and no deviations are being allowed. The quotation will not be considered if any deviation found in the above terms and conditions.
13. **The EMD will be forfeited**, if the firm fails to execute the work after placing the work order.
14. The materials proposed to be used shall be got approved by Institute's Officer before installation. The work is to be carried out in consultation with Institute's Officer.
15. The Street Lights & Bollards shall be **under warranty for 2 years**.
16. The rate quoted will be valid for a period of 6 months for repeat orders, if any (with 50% increase in quantity) from the date of placing of this work order.

## Eligibility Criteria

- (A) **Work Experience:** Minimum 5 years of experience in the field of undertaking similar works viz SITC of Street Light & bollard system for large office buildings / commercial Estate / industrial houses (as on November, 2016).
- (B) **Annual Turnover:** The applicant should have a minimum yearly turnover of Rs. 20.00 lac during the last 3 financial years ending March 31, 2016.
- (C) The applicant should have a service set up in Hyderabad for rendering after sales service

## Conditions for Tender

1. Tenderers are required to submit filled up and completed tender documents in original as Technical Bid (Part I) and Price Bid (Part II) in duplicate in a sealed cover, as mentioned below:
2. Sealed Envelope No.1, the Technical Bid (Part I), should contain the following:
  - a) **Earnest Money Deposit for tender of Rs 15,000/- (Rupees Fifteen Thousand only)** in the form of Demand Draft drawn in favor of "Institute for Development and Research in Banking Technology", Hyderabad.
  - b) Details filled up as per Format at Annexure – A along with Form of Tender duly filled in.
  - c) One hard copy of Part I (Conditions of Contract), duly stamped with tenderer's seal and signed on each page.
  - d) All submittals – as per instructions to Tenderer, Tender Conditions, and Addendums (if any) and as per list mentioned below, failing which the tender will not be considered:
    - (a) Details and supporting documents (self attested) as called up in format at Annexure 'A'
    - (b) Prescribed E.M.D for tender.
    - (c) Part I, corrigendum / addendum issued, if any, duly stamped and signed on each page in token of acceptance thereof.
  - e) This envelope shall be super scribed "Envelope No 1 – (TECHNICAL BID) for the work of SITC of Street lights & Bollards in IDRBT premises.
- 3 **Sealed Envelope No. 2, the Priced Bid (Part II), should contain the following:**

- a) One hard copy of the Priced Bill of Quantities; Part II in original, duly filled in, stamped and signed on each page by the tenderer.
- b) Unit rates shall be quoted against each item of BOQ. The item rates quoted must be written in figures as well as in words against each item. In case of discrepancy between the two, those written in words shall take precedence. The item rate quoted should correspond to the “units” given under unit column.
- c) Commercial or technical conditions or clarifications of any sort shall not be indicated by the tenderer in Envelope No.2; otherwise the tender shall be rejected.
- d) This envelope shall be superscripted “Envelope No.2 – (PRICE BID) SITC of Street lights & Bollards in IDRBT premises, Hyderabad
- e) Both envelopes 1 & 2 should be put in another single double sealed cover [Envelope 3] and sealed with sealing wax and addressed to the Accepting Officer at the address given below: and dropped in the tender **box before 17.00 hrs on 28.11.2016**

THE ASSISTANT GENERAL MANAGER (ESTATE)  
INSTITUTE FOR DEVELOPMENT AND RESEARCH IN BANKING TECHNOLOGY (IDRBT)  
(Established by Reserve Bank of India)  
CASTLE HILLS, ROAD NO. 1  
MASABTANK, HYDERABAD - 500057

- f) *The sealed envelope 3 containing envelope 1 and envelope 2, shall be super scribed with the following details:-*

NAME OF THE WORK,  
TENDER NOTICE No.

- 4 The tenderers are advised to visit the site at IDRBT, with prior appointment with the Accepting Authority, IDRBT, Hyderabad giving sufficient time. Tenderers shall be deemed to have full knowledge of all relevant documents, site etc., whether they have inspected them or not.
- 5 The following requirements shall be **strictly complied with**
  - i) Tenderers shall affix their signature and seal on all pages of the tender documents and all the enclosures accompanying the tender documents before submission of the tender.
  - ii) All tender documents received shall be filled, signed with seal and submitted in the original only, failing which tenders will not be considered.
  - iii) Tenderers shall ensure that their tender is dispatched well in advance, so that it reaches the office of the AGM (Estate) or should be deposited in the tender box kept in the IDRBT Security Office, before the time & date stipulated in the introductory paragraph of this tender document.
- 6 **The tender will be evaluated and accepted on overall basis.**

Yours faithfully

**For Institute for Development and Research in Banking Technology  
(IDRBT)**

**The Asst General Manager (Estate)  
Issuing & Accepting Officer**

**PROFILE OF THE TENDERER**

1. Name & address of the Tenderer :  
Tel No :  
E-mail :  
Fax No :  
Mobile (of Contact Person) :
2. Legal status of the tenderer :  
(Proprietary/Partnership/Company/PSU-  
Attested copy as supporting document  
like affidavit, partnership deed, memorandum  
of articles of association as applicable to be attached)
3. Name of the Authorized Signatory :  
(power of attorney to be attached if  
tender is signed by person other than  
Director, Partners or Proprietor)
4. PAN No. for Income Tax :  
(Attested copy to be attached)
5. Service tax registration No. :  
(Attested copy to be attached)
7. Details of Financial Turnover during the last 3 years:-

<b>Year</b>	<b>Amount (in Rs.Lakhs)</b>	<b>Reference of supporting documents &amp; attachment nos.</b>
2013 – 14		
2014 – 15		
2015-16		

8. Details of satisfactorily completed similar works performed during the last three years (attested copies of completion certificates issued by the clients to be attached). Attach a separate sheet if necessary.

Name of client/ Company	Details of nature of works executed	Actual Date of start & completion	Value of the contract completed	Full contact details of Company / Client

\* Only details of completed contracts are to be entered.

9. At any time in the last three years, has your firm been assessed for and paid liquidated damages after completion of a project under a construction contract?

YES / NO

If yes, give details:

10. Details of E.M.D. for tender:

Amount in Rs.....

DD NO/ BG No.& Date .....

Name of the Bank .....

11. Enclose attested copies of Income Tax returns for the last three financial years ending 31<sup>st</sup> Mar 2016

**12. DECLARATION:**

I / We declare and confirm that:

- a) All information and attachments submitted in Annexure - A are true and correct.
- b) I / We are aware that any information provided herein found to be false at a later stage will result in the rejection of my / our tender even if it is the lowest tender.

**SIGNATURE OF AUTHORISED SIGNATORY (SEAL)**

Name of Authorized Signatory :  
Date :

## Price Bid

### Supply and installation of street light & cable work at IDRBT, Hyderabad.

S.no	Description	Qty	Units	Rate	Rate in Words	Amount
1	Supply, Laying, Testing & Commissioning of <b>30W Premium Street Light</b> Fitting as per the fig no.1 (single lens) including 3C X 1.5sqmm Copper Armored Cable Laid on wall or 1-2 feet underground from DB to Pole and 3C X 1.5Sqmm flexible wire for Pole to street Light including Arm, Modification of Pole, excavation & refilling of soil, Civil Work and providing each pole with Individual control & MCB if necessary accessories. Note: Light & Arm should be in Black color					
a	Item Code:092306 of Ayana Make-30 W <b>OR</b>	40	Nos.			
b	SSK-SLR-30W of Syska LED make	40	Nos.			
2	Supply, Laying, Testing & Commissioning of 10W Bollard Light Fitting as per the fig No.2 including 3C X 1.5sqmm Copper Armored Cable laid on wall or 1-2 feet underground from DB to Light with excavation & refilling of soil, Base, Civil Works and providing three/ four/ five lights controlled by one MCB with necessary accessories etc complete work. (Height of bollard is 3 feet)					
a	Item Code:14510-3 - 10 W of Ayana make <b>OR</b>	50	Nos.			
b	Syska make for 10 W	50	Nos.			

3	Supply and Fixing, Testing, Termination of Outdoor type 4Way TPN Double Door DB with Suitable MCB'S including Laying of Incoming cable for DB with excavation & refilling of soil, Civil Works etc (Incoming Cable 4C X 4sqmm Copper Armored Cable). Make: Legrand.	2	Nos.			
4	Removing of unused street light poles and termination of the old cable etc. including civil works, excavation & refilling of soil complete for finished item of work as directed	25	Nos.			
5	Supply and painting with two coats of Black Enamel paint over one coat of red oxide primer after scraping and cleaning old paint over the street light poles including cost and conveyance of all materials like paint, brushes, lifting charges and labor charges such as preparing the pole, etc. complete for finished item of work.	40	Nos.			
6	Re-fixing of removed street light poles with necessary civil works complete for finished item of work	5	Nos.			
<b>Grand Total:</b>						

**Note:**

1. Cable Make: Polycab
2. The rates must be inclusive of all taxes

**Signature of the Firm**



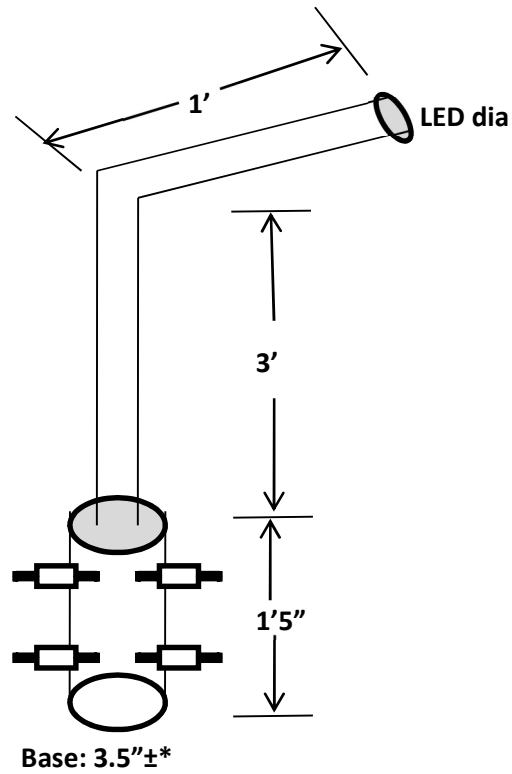

LED  
LIGHT

\* Suitable existing pole dia

**Fig.No. 1**  
**ARM & LED Street Light**



**Fig No.2**  
**LED Bollard Light**